

# 158 MAINTENANCE

## Master Cylinders

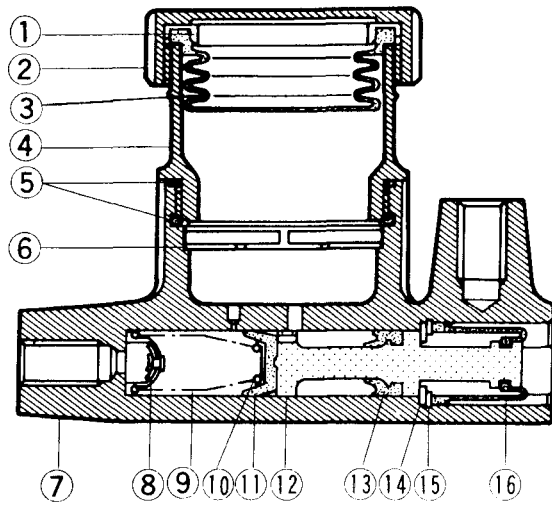

- |                         |                    |
|-------------------------|--------------------|
| 1. Ring Plate           | 8. Check Valve     |
| 2. Cap                  | 9. Spring          |
| 3. Diaphragm            | 10. Spring Seat    |
| 4. Reservoir            | 11. Primary Cup    |
| 5. O Rings              | 12. Piston         |
| 6. Plate                | 13. Secondary Cup  |
| 7. Master Cylinder Body | 14. Piston Stopper |

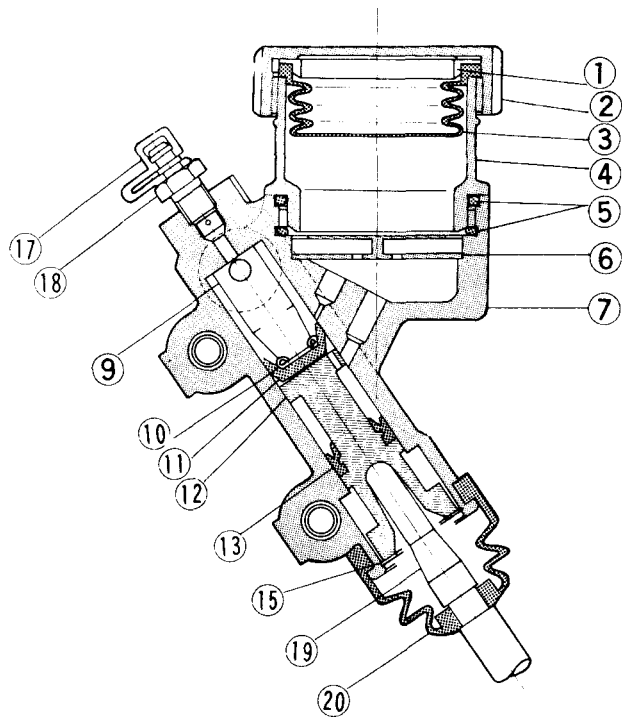

- |                     |                 |
|---------------------|-----------------|
| 15. Circlip         | 18. Bleed Valve |
| 16. Dust Seal       | 19. Push Rod    |
| 17. Bleed Valve Cap | 20. Dust Cover  |

## Caliper

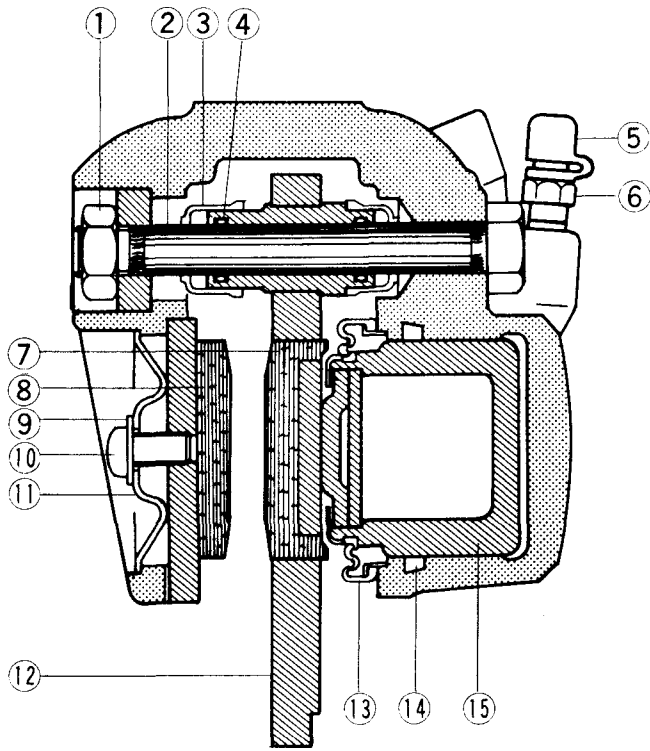

1. Nut
2. Caliper Holder Shaft
3. Dust Cover
4. O Ring
5. Bleed Valve Cap
6. Bleed Valve
7. Pad A
8. Pad B
9. Lock Washer
10. Screw
11. Metal Plate
12. Caliper Holder
13. Dust Seal
14. Fluid Seal
15. Piston