

142 MAINTENANCE

Shift Mechanism

482

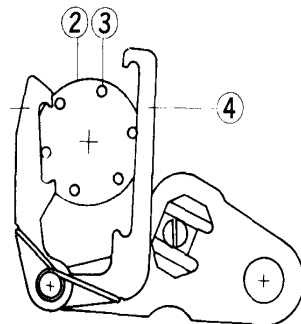
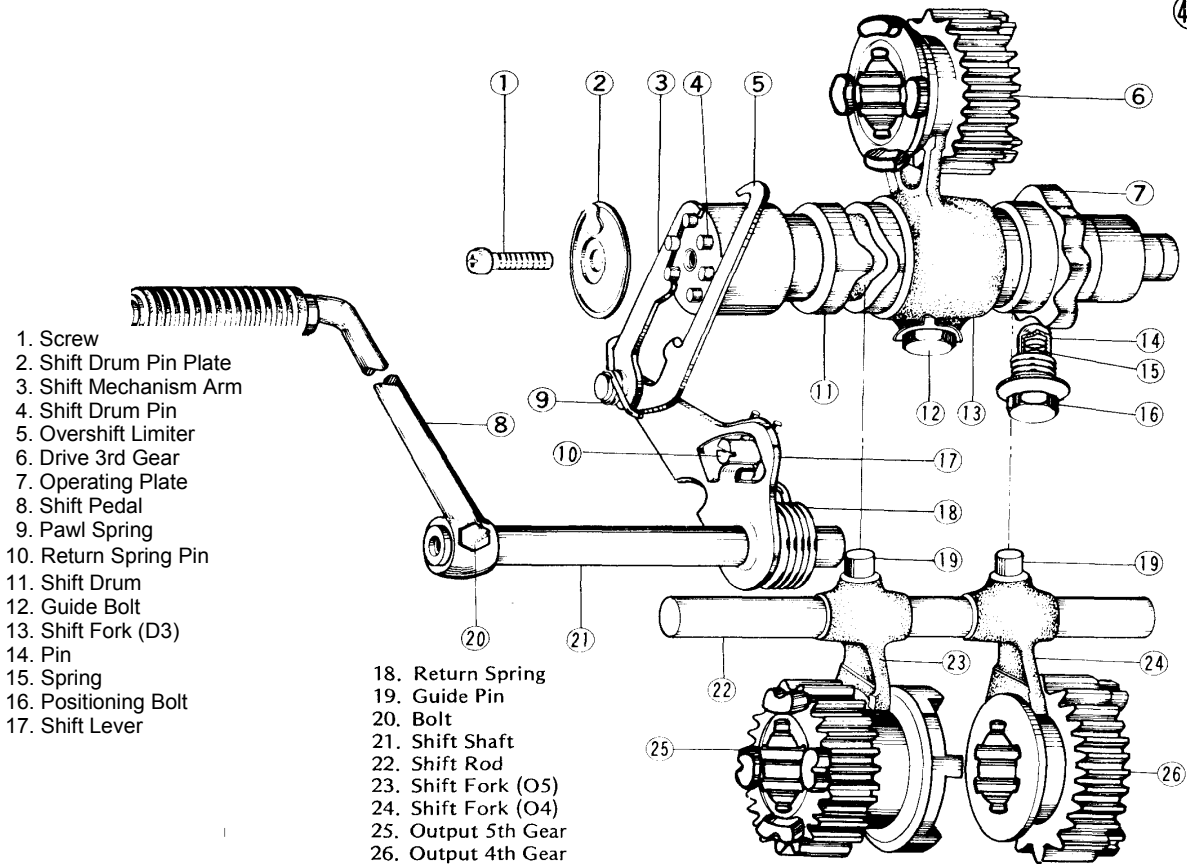

beyond the intended gear position, particularly on a fast shift. At the same time, the overshift limiter arrests the shift lever's motion at the end of the stroke to aid in preventing overshifting.

Neutral Indicator Switch

A neutral indicator light is provided so that the rider

Shift Mechanism Arm and Over Shift Limiter Operation

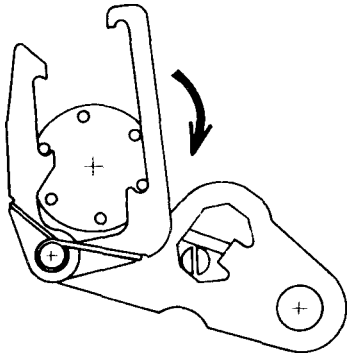

can readily determine whether or not the transmission is in neutral. The neutral indicator switch, installed in the external shift mechanism cover, consists of a spring loaded pin which contacts a nub on the shift drum pin holder when the transmission is in neutral. This completes the neutral indicator light circuit, which turns the neutral indicator light on.

- 1. Shift Mechanism Arm
- 2. Shift Drum

- 3. Shift Drum Pin
- 4. Overshift Limiter

