

Front Turn Signal Installation

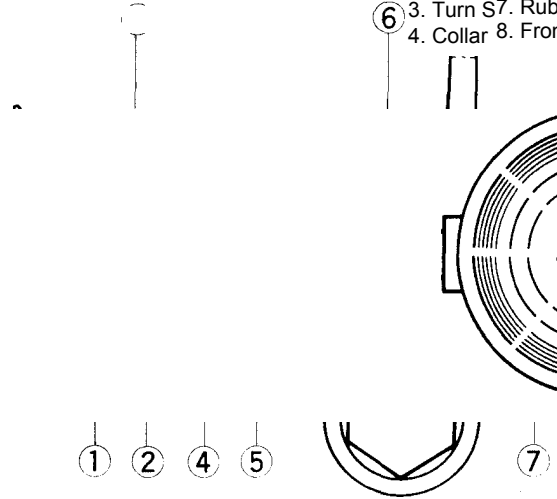

DISASSEMBLY 101

1. Nut
2. Lock Washer
3. Turn Signal
4. Collar
5. Rubber Damper
6. Fork Cover
7. Rubber Damper
8. Front Turn Signal

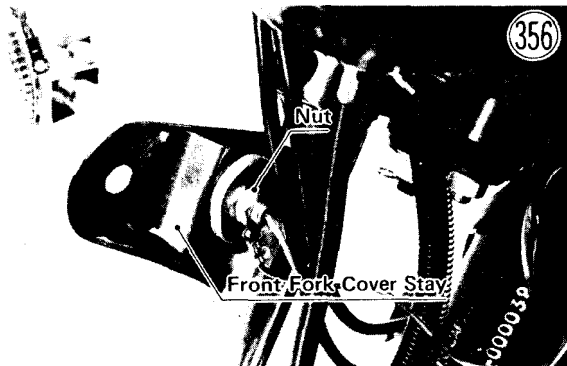

3. Adjust the headlight vertically (Pg. 21).

Removal (rear, either side):

- Unlock the seat and swing it open.
- Disconnect the turn signal gray lead.



Installation Notes (front, either side):

1. If the front turn signal dampers have been removed, install them as shown in Fig. 355.
2. Connect the turn signal leads referring to Table 8.

Table 8 Turn Signal Lead Color

	Turn Signal Lead	Main Wiring Harness Lead
Right	Gray Black/Yellow	Gray Black/Yellow
Left	Gray Black/Yellow	Green Black/Yellow

Remove the nut and lock washer, and pull the rear turn signal from the frame.

Installation Notes (rear, either side):

If the rear turn signal dampers have been removed, install them as illustrated.

1. Nut
2. Lock Washer
3. Flat Washer
4. Turn Signal
5. Collar
6. Rubber Damper
7. Frame
8. Rubber Damper
9. Rear Turn Signal

Rear Turn Signal Installation

